



The **EXXOTEST<sup>®</sup>** DT-M005 model is a teaching support that allows observing the basics of automotive electricity and studying the fundamental laws such Ohm's law ( $U = RI$ ) as well as the serial / parallel arrangements.

## OBJECTIVES

The features of the DT-M005 module facilitate learning of the electricity's basics.

The student has an opportunity to carry out several wirings and to achieve the fundamental laws of automotive electricity due to utilization of some real electrical components on this teaching module. It allows to apply easily the theoretical knowledge on practice:

- Check and use the basic laws of electricity
- Perform a voltage divider bridge

The main wirings are:

- Bulbs' wiring (serial, parallel)
- Resistances' wiring (serial, parallel)
- Switches' wiring
- Relays' wiring

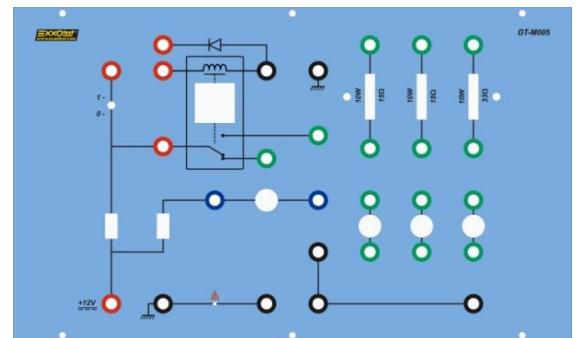

The **DT-M005** also gives the possibility to choose the correct fuse calibration and to measure voltages and currents at each point of the created circuit. This module provides:

- Maximum safety for the user;
- Protection against mishandling (overvoltage, polarity's reverse);
- Easy access for wirings and measurements.

## DESIGN



- 2 10W / 15Ω resistance and one 10W / 33Ω resistance
- 4 bulbs 12V 5W
- 1 relay RT 20/30A 12V on terminals
- 1 two-positions switch
- 2 fuses
- Power and mass sockets
- Switch-mode 12V 25A power set supplied with the module

Example of a wiring diagram:

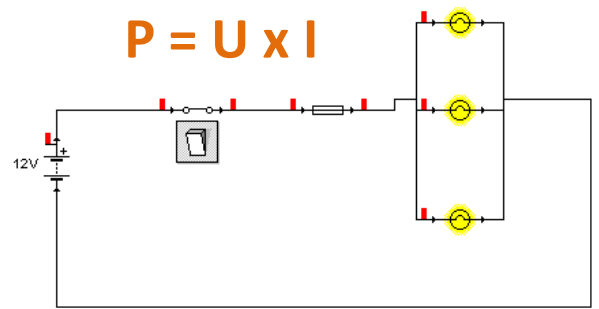
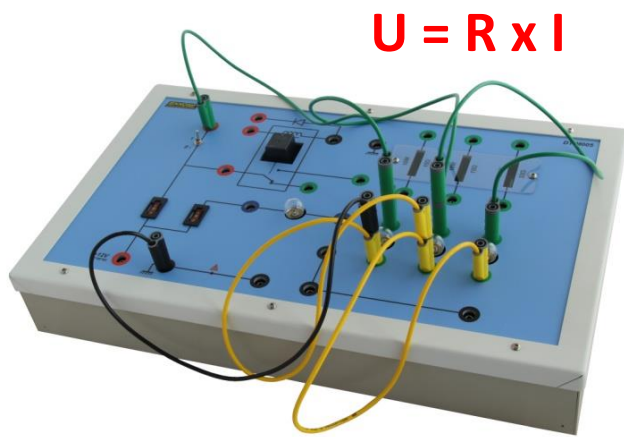

$$U_2 = U \times (R_2 / (R_2 + R_1))$$

## ACCESSORIES

This module may be associated with the **GI3000** that allows powering the bulbs in PWM-mode\*. You can approach this principle increasingly used on newer vehicles: a single bulb can be used simultaneously for stop lamp and position lamp; just its power will change.

\***PWM**: *Pulse Width Modulation* - The bulbs' power duration is variable and depends on frequency that explains a variable light intensity.

## OTHER

- Delivered with:
  - use and teaching instruction book,
  - banana plug cable assemblies according to the module needs,
  - ALF2902M stabilised adjustable alimentation (from 5V to 29V, 3A).
- Power supply: 220/110Vac – 50/60Hz.
- Size: 600 X 400 X 300 mm (transportation box).
- Gross weight : 6 Kg (ready to ship).
- Net weight: 5 Kg.

Find all **EXXOTEST**<sup>®</sup> products on the Internet: [www.exxotest.com](http://www.exxotest.com)